

## SECTION 2 ADJUSTMENT PROCEDURES

### 1. DISASSEMBLY METHOD FOR CABINET

#### 1-1. Top Cover

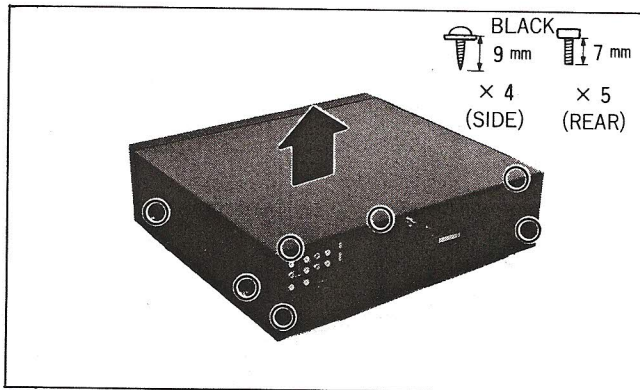

Fig. 1-1 Top Cover

Remove 7 screws, then lift the rear of the Top Cover to remove.

#### 1-2. Front Panel

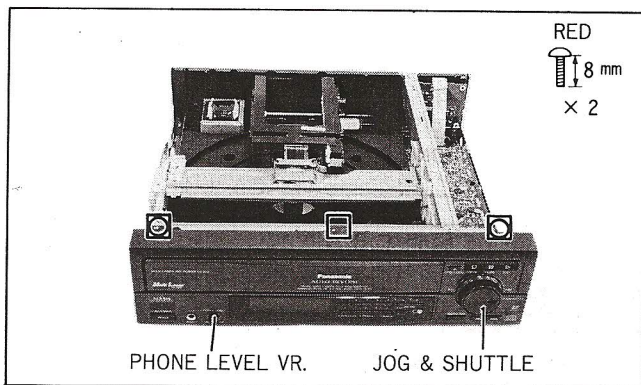

Fig. 1-2 Front Panel (top view)

1. Pull out the Phone Level VR. knob and Jog & Shuttle dial on the Front Panel.
2. Remove 2 screws and unlock 3 locking tabs on the top side.

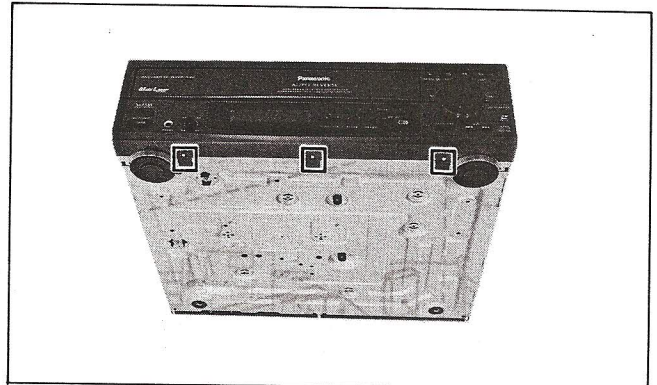

Fig. 1-3 Front Panel (bottom view)

3. Unlock 3 locking tabs on the bottom side. Then, hold the top portion of the panel and turn it toward the front side of the unit.

## 2. HOW TO MANUALLY EJECT DISC TRAY

If the Disc Tray can not be ejected normally, it is possible to eject the Tray manually as follows:

#### NOTE:

Work with extreme care when there is a Disc inside the Tray compartment and do not turn the unit on it's side when in step "2" of this procedure.

1. Remove Top Cover (Refer to Fig. 1-1).
2. Turn the Brake Gear counterclockwise slowly until the Tray has fully ejected.

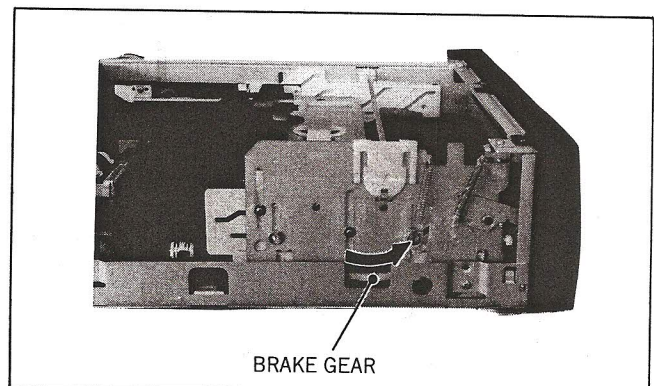

Fig. 2-1 Manual Eject

### 3. LOCATION OF C.B.A

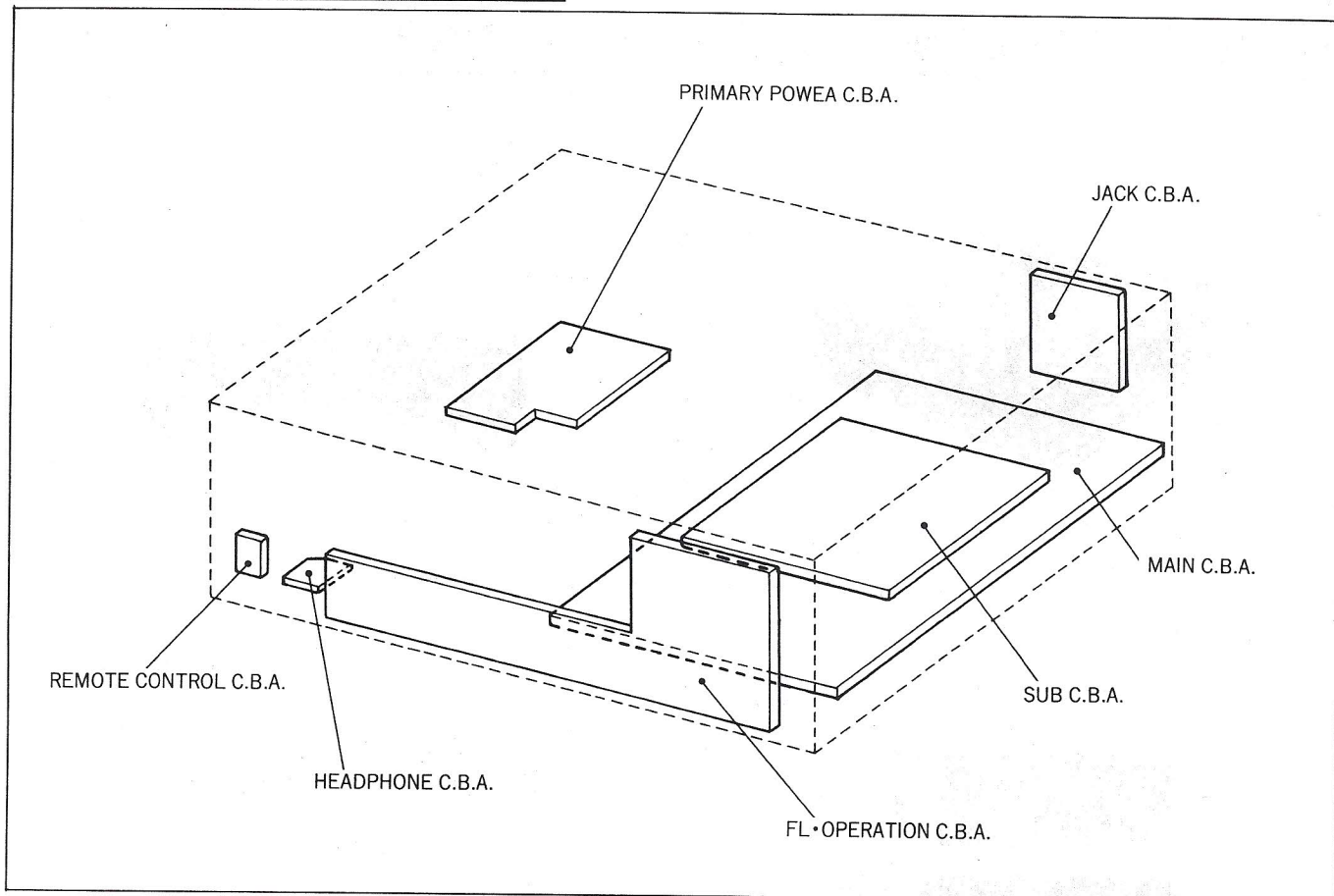

Fig. 3-1 Location of each C.B.A.

### 4. DISASSEMBLY METHOD FOR C.B.A

When checking the Main & Sub C.B.A.s, each C.B.A. must be removed from the right side of the unit in the following order.

4-1. FL. Operation C.B.A.

1. Remove the Top Cover, Front Panel and Tray.
2. Remove 7 screws and unlock 10 locking tabs. After that, disconnect FP26001 flat cable on the Operation C.B.A.

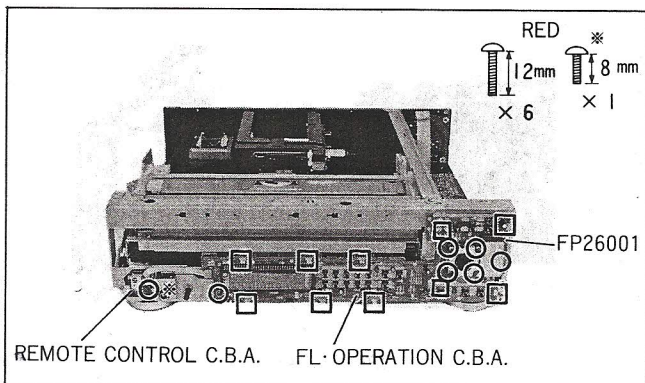

Fig. 4-1 FL. Operation C.B.A.

4. Remove 5 screws and unlock 1 locking tab on the Jack Unit.

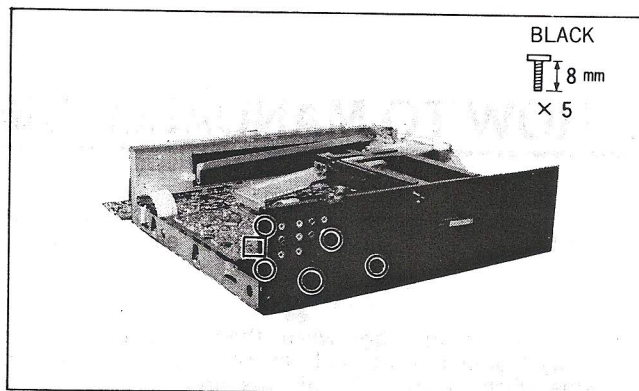

Fig. 4-2 Jack Unit

3. Remove Right Bracket unit, Drive Gear, Syncro. Gear, Clamp Plate and Shaft Holder as shown in Fig. 6-3 and 4.

5. Remove 4 screws and disconnect the flat cable FP22001, FP22003 and connector P22002, P21002. Then carefully remove the Main & Sub C.B.A. from the right side of the unit as shown in Fig. 4-4.

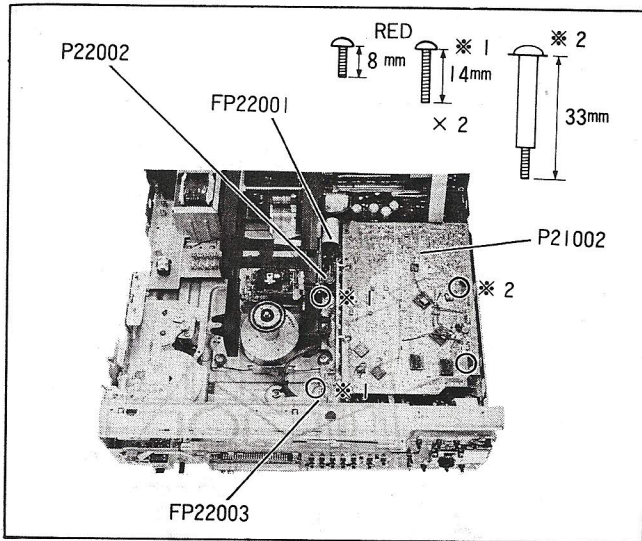

Fig. 4-3 Main & Sub C.B.A.

6. Set the Right Bracket with Rack Plate (R), Tray Guide Plate (R), Syncro. Gear, Drive Gear and Shaft Holder as shown in Fig. 6-4. And also set the Tray as shown in Fig. 6-2.
7. Connect the Extension Cables, FP26001 on FL. Operation C.B.A. as shown in Fig. 4-4 and 5.

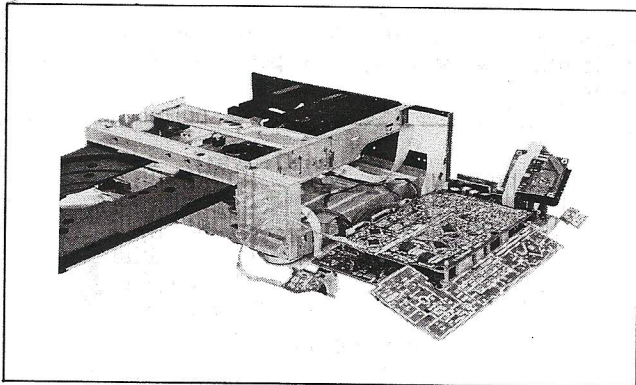

Fig. 4-4 Service Position 1

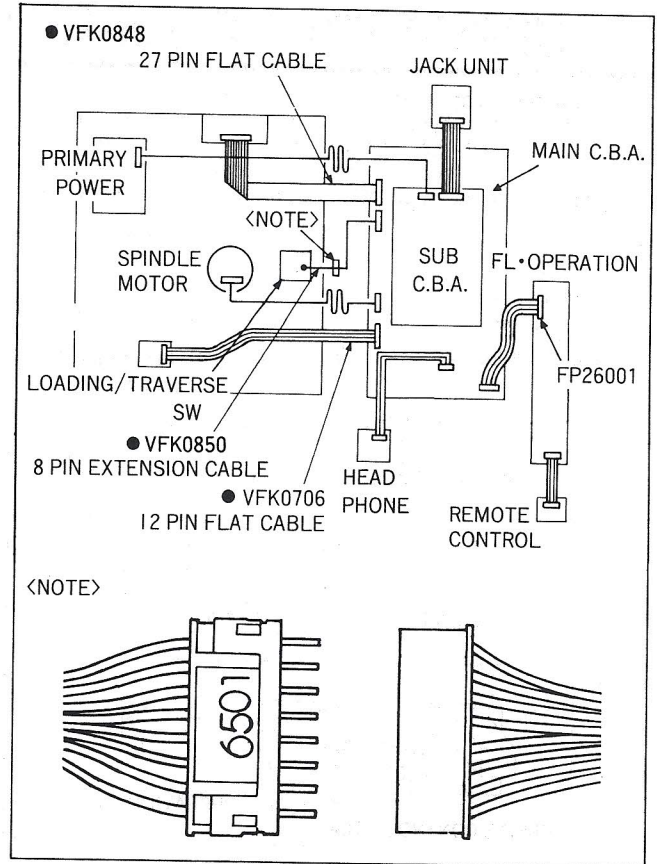

Fig. 4-5 Service Position 2

VFK0706	12 PIN FLAT CABLE	FP22003 (MAIN) FP26203 (LOADING SW)
VFK0848	27 PIN FLAT CABLE	FP22001 (MAIN) FP25012 (INTERFACE)
VFK0850	8 PIN EXTENSION CABLE	P22002 (MAIN) LOADING/TRAVERS SW

<NOTE>

Connect the Extension Cables VFK0706 so that the character side of the cable faces upward. Then connect the Extension Cable VFK0848 so that the character side faces upward on the Interface C.B.A. side and the character side faces downward on the Main C.B.A. side as shown in Fig. 4-4. Connect the VFK0850 is shown in Fig. 4-5.

# 5. SUPPER TRAP CONNECTOR (BLUE) CONNECTOR

The Supper Trap Connector is used in each C.B.A. There are two types of this connector, V and H, which are used as shown in Fig. 5-1. The cable with the V type connector can remove from connector. The H type connector can not remove.

<Removal of the jumper wire for V type connector>

Pull the flat cable out while pushing against the <PUSH> portion of the Supper Trap Connector in the direction indicated by arrow as shown below.

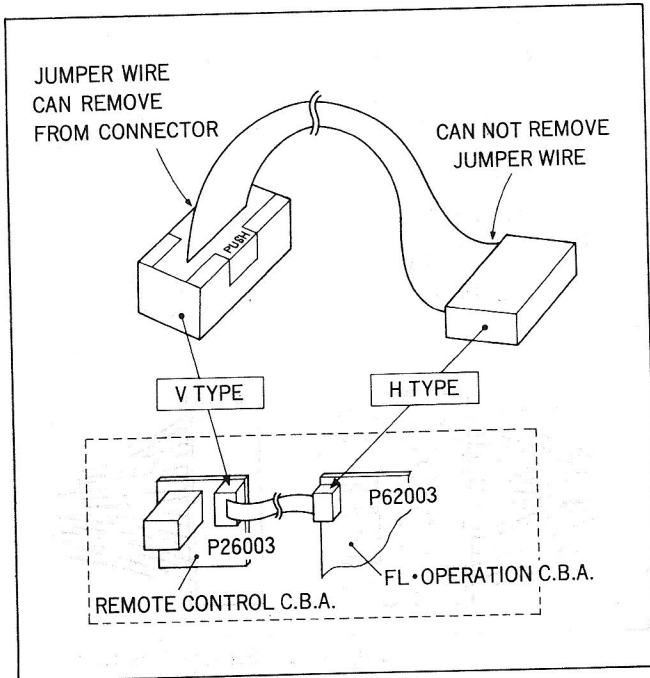

Fig. 5-1 V & H Type of Connector

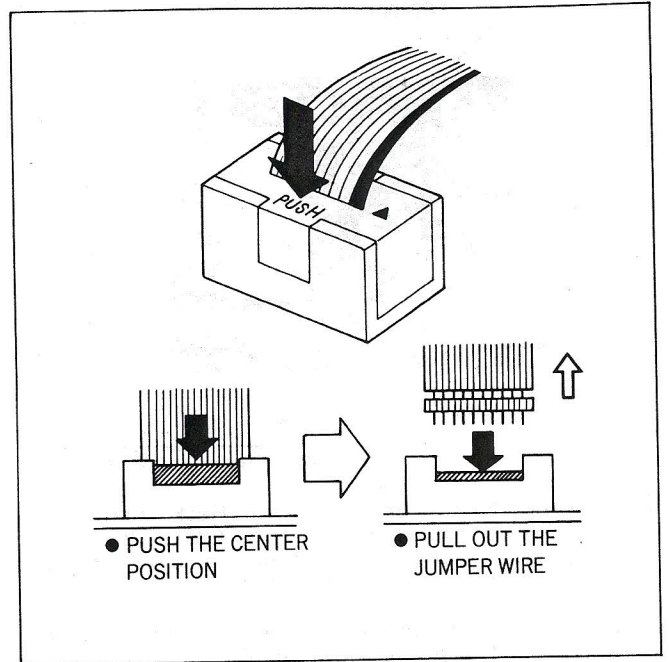

Fig. 5-2 Unplug

When you install the flat cable, set the wire to horizontal by shifting the position (A) as shown below.

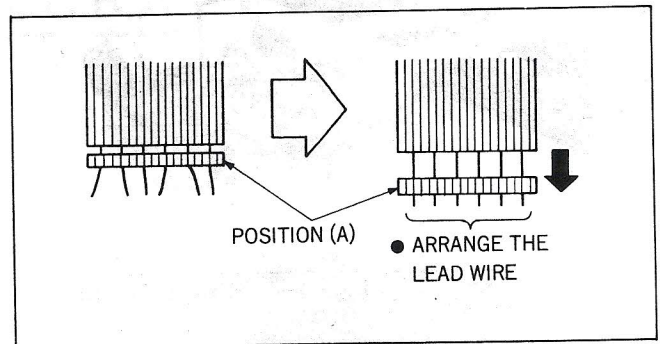

Fig. 5-3 Plug In

After plugging in the flat cable, make sure that the <PUSH> portion of the connector has returned to its original position.

# 6. REPLACEMENT OF MECHANICAL PARTS

## (1) Replacement of the Tray

### <Removal of the Tray>

1. Set the mechanism to the Eject position. (Refer to Fig. 2-1)
2. Remove 1 screw (A) on the Tray and then carefully remove Tray as follows:

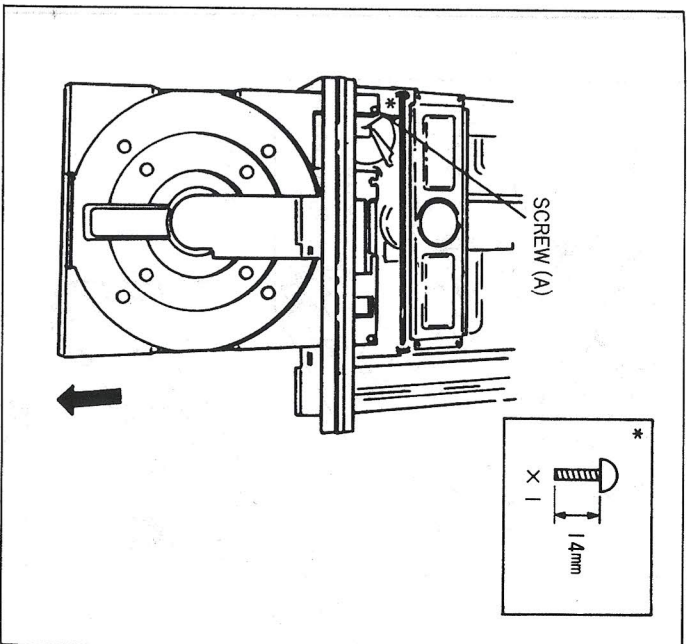

Fig. 6-1

### <Tray installation>

1. Turn the Tray Drive Gear fully counter-clockwise.
2. Then install the Tray so that the Mark (B) on the Tray Drive Gear meets the first Gear (A) of the Tray. Then install screw (A).

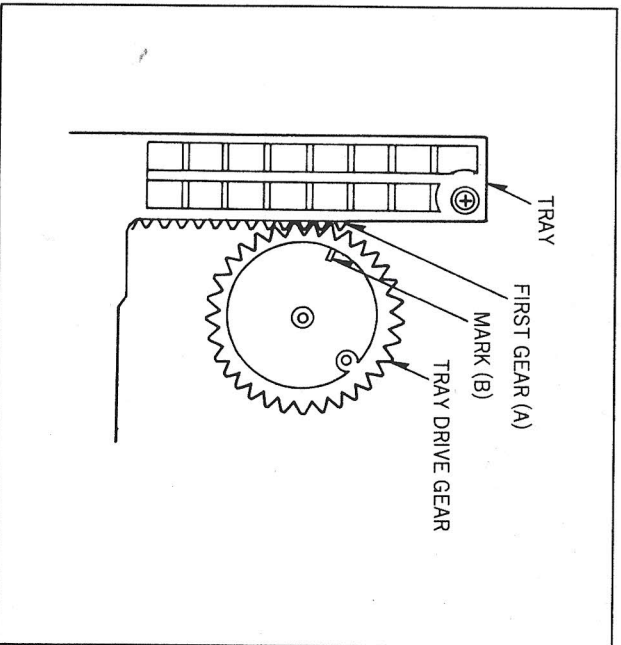

Fig. 6-2

## (2) Replacement of the Tray Drive Section

### <Removal>

1. Remove the Tray and Front Panel (Refer to Fig. 1-2, 3 and Fig. 2-1)
2. Unlock the Locking Tab (A) on the Charge Holder by pushing to rear side. Then shift the Charge Holder to front side to remove it.
3. Remove the Clamp Plate.

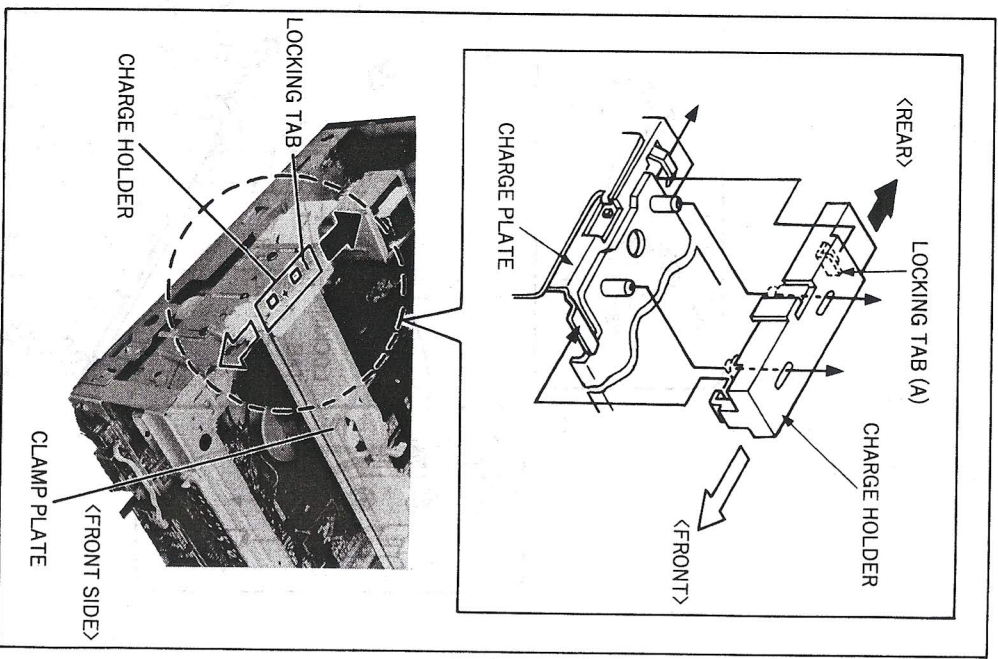

Fig. 6-3

- Remove 2 screws (B) to remove the Right Bracket with Rack Plate (R) and Tray Guide Plate (R).

The Rack Plate (R) and Tray Guide Plate (R) can be removed from the Right Bracket by removing 2 screws (C) as shown in Fig. 6-4.

- Remove the Drive Gear Shaft and Syncro. Gear. Then remove the Shutter by removing screw (D). Remove the Shaft Holder by unlocking 2 locking tabs.

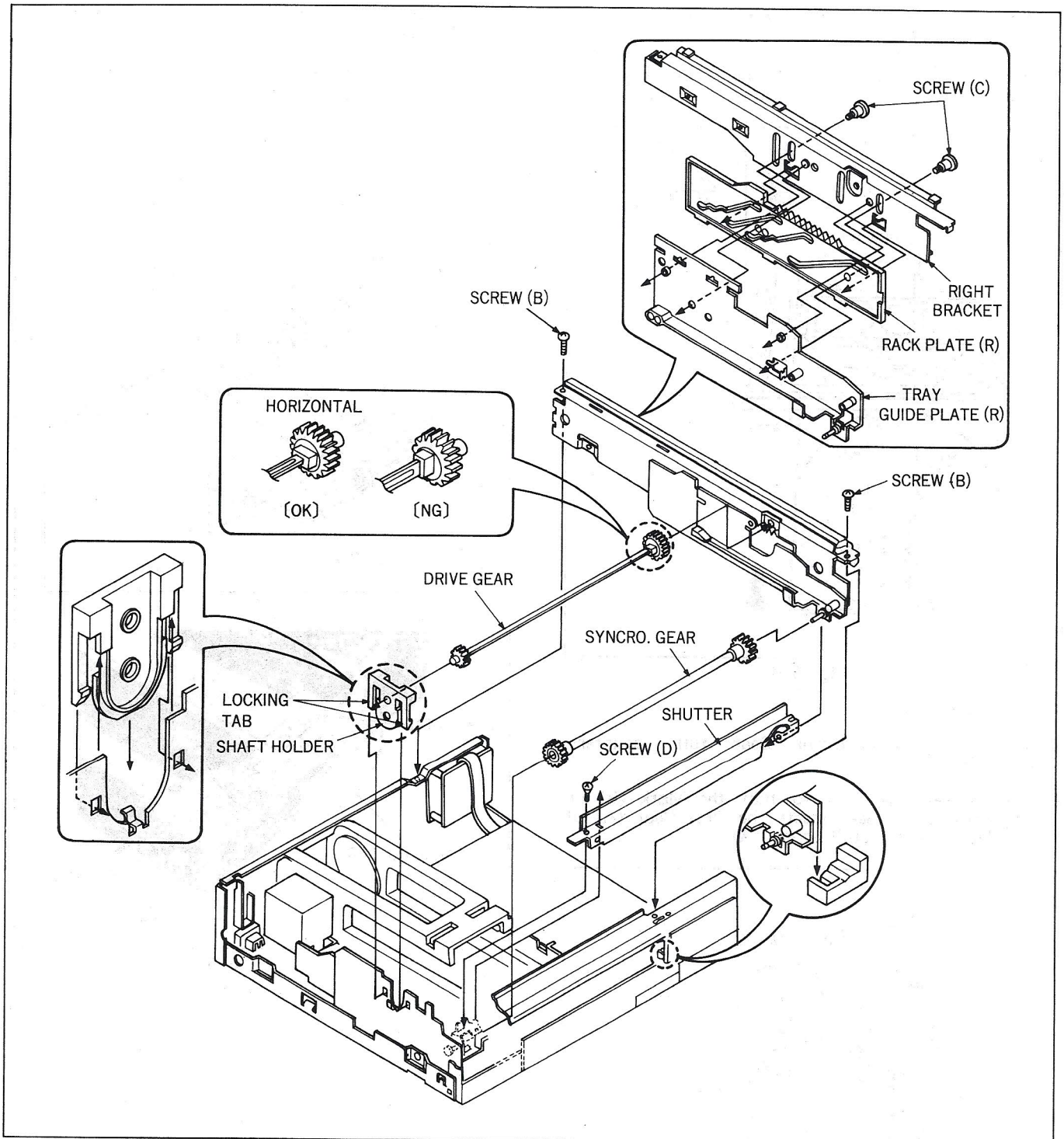

Fig. 6-4

6. Disconnect FP26203 and remove 3 screws (E). Then take out the Loading Unit as shown in Fig. 6-5.

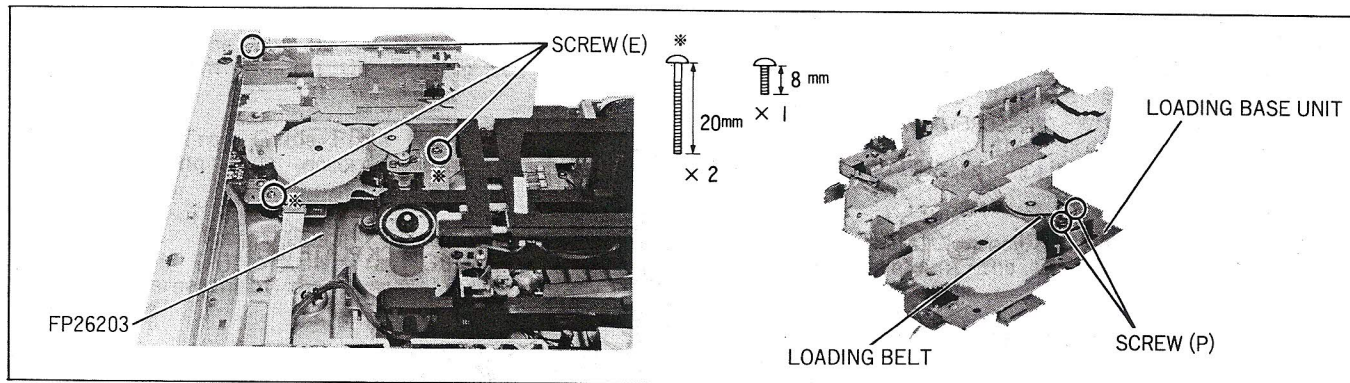

Fig. 6-5

<NOTE>

When replacing the Loading Motor and each switch under the Cam Gear the Loading Unit must first be removed.

7. Remove 2 cut washers (F) and washer (G) on the Left Bracket to remove the Charge Plate.

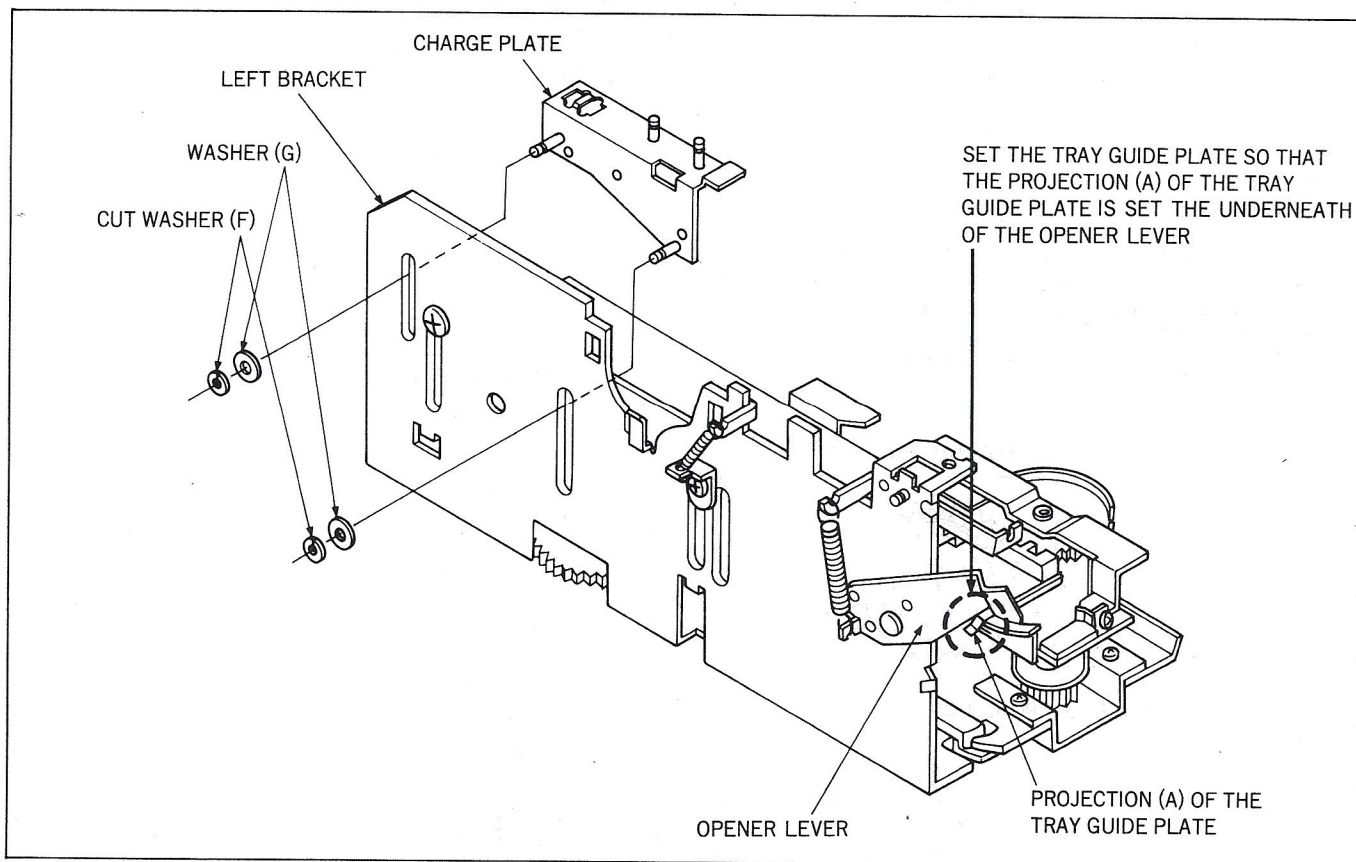

Fig. 6-6

8. Remove screw (H) and spring (I) to remove Shutter Support Angle.
9. Remove the Tray Drive Gear, Tray Guide Plate (L) Rack Plate (L) and Support Spring by removing 2 screws (J), cut washer (K), E Ring

(L) and Drive Gear Shaft (M) as shown in Fig. 6-7.

10. Remove cut washer (N) to remove Main Gear.

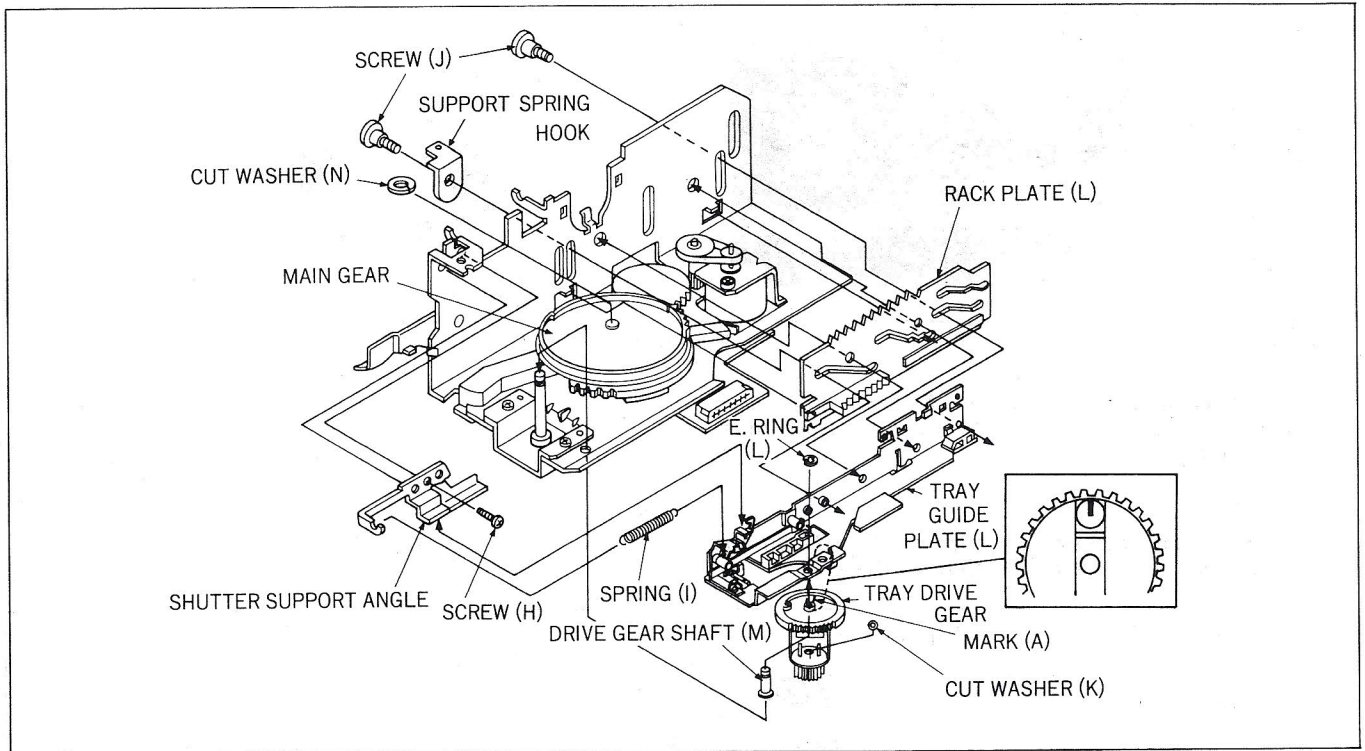

Fig. 6-7

<Reassembly>

1. Install the Main Gear so that the projection (B) on Lock Lever meets the slot (A) under the Main Gear. Then install the cut washer on the Main Gear mount.

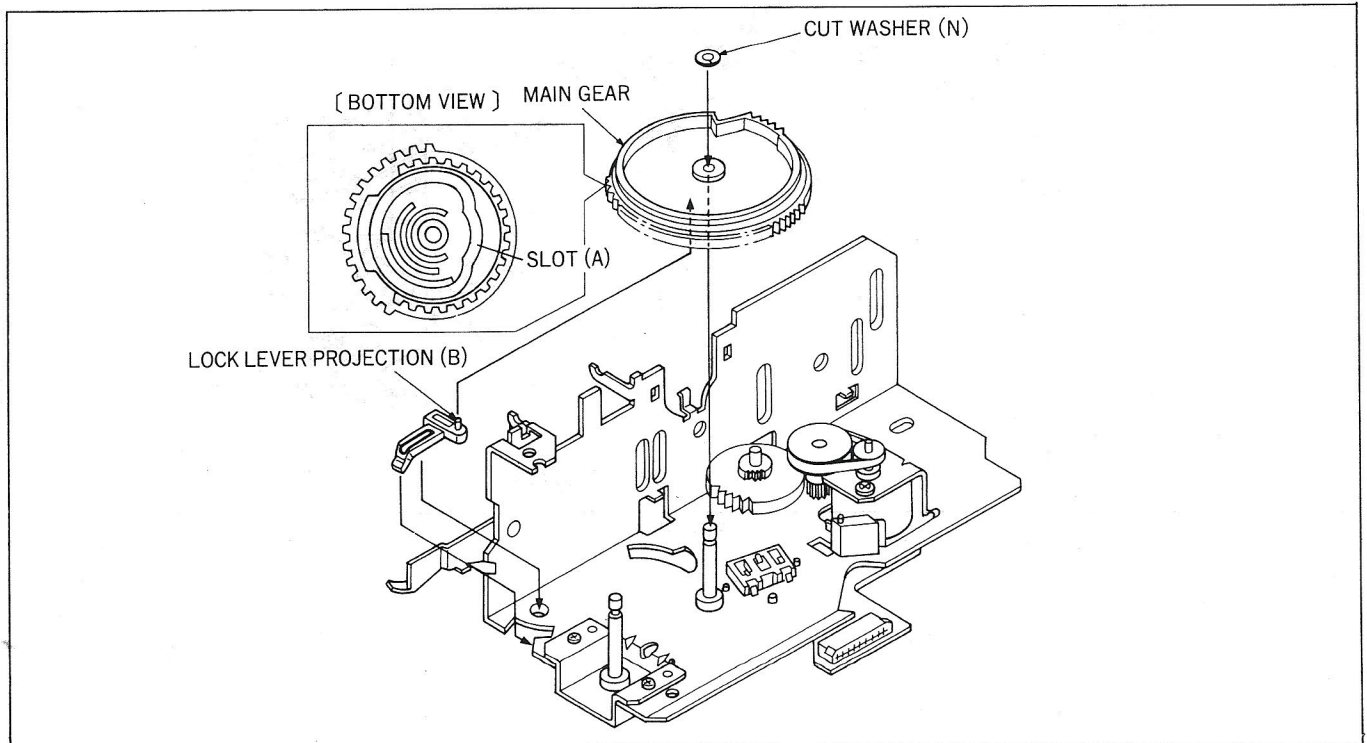

Fig. 6-8



2. Set the Mark (A) rotate the Main Gear until Mark (A) is on the left side as shown in Fig. 6-9.
3. Install the Drive Gear Shaft from bottom side to hole of the Tray Drive Gear and Tray Guide Plate (L). Then install the E-Ring (L) as shown in Fig. 6-7.
4. Align the Tray Guide Plate (L), Rack Plate (L) and Loading unit according to the following items:
  - (a) Set the Tray Guide Plate so that the projection (A) of the Tray Guide Plate is set the underneath of the Opener Lever as shown in Fig. 6-6.
  - (b) Install the Tray Drive Gear so that the Mark (A) on the Tray Drive Gear which is seen through hole on the Tray Guide Plate (L) is set to center as shown in Fig. 6-7.

Then install 2 screws (J) to mount the Loading Unit through Support Spring Hook as shown in Fig. 6-7.
5. Install the Charge Plate then install 2 washers (G) and 2 cut washers (F) so as to mount the Loading Unit as shown in Fig. 6-6.
6. Install the Shutter Support Angle then install screw (H) so as to mount the Loading Unit as shown Fig. 6-7.
7. Install the Loading Unit Assembly by installing 3 screws (E) and connect FP26203 as shown in Fig. 6-5.
8. Install the Syncro. Gear and Shutter on Tray Guide Plate (R). Then install the Right Bracket with Rack Plate (R) and Tray Guide Plate (R). Install 2 screws (B) as shown in Fig. 6-4. Install the Drive Gear with Shaft Holder to Right Bracket so that projection on the Drive Gear faces upward (horizontal) as shown in Fig. 6-4.
9. Install the Clamper. Then set the Charge Holder to mount the Clamper as shown in Fig. 6-3.

### (3) Replacement of the Loading Motor

1. The Loading Unit must first be removed when replacing the Loading Motor as shown in Fig. 6-5 (Left).
2. Remove 2 screws (P) and Loading Belt and then remove Loading Motor from bottom side of the Loading Unit as shown in Fig. 6-5 (Right).

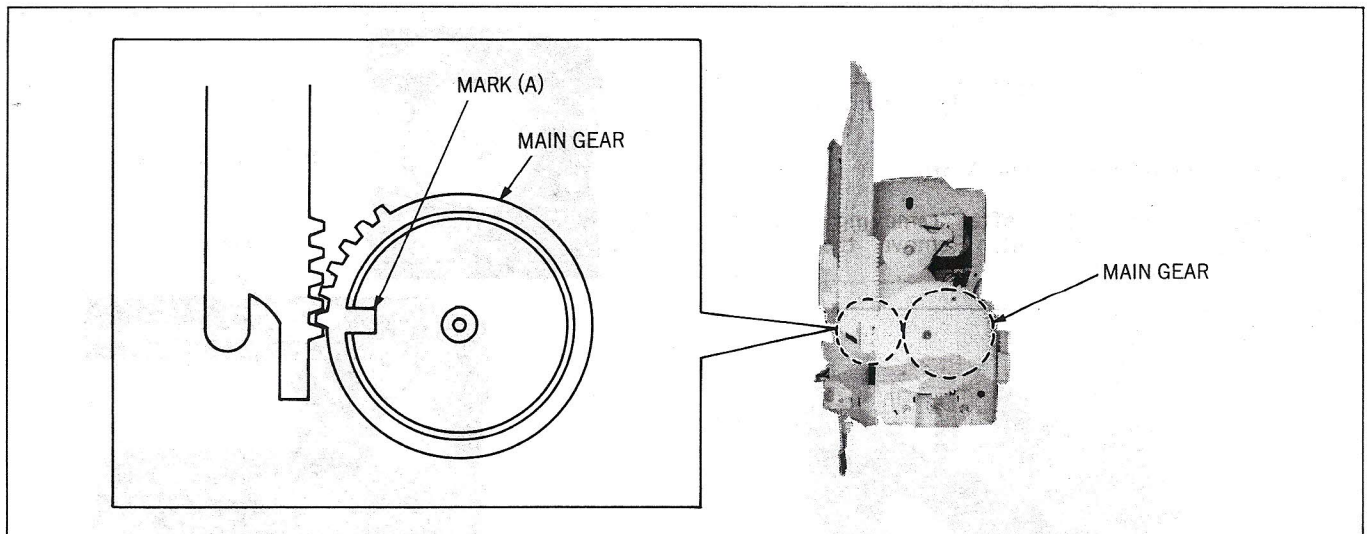

Fig. 6-9

# 7. REPLACEMENT OF TRAVERSE SECTION

## (1) Replacement of the Traverse Unit

1. Remove the Charge Holder and Clamp Plate (Refer to Fig. 6-3).

2. Disconnect the following connectors.

FP250011 Interface C.B.A.  
 FP250012 Interface C.B.A.

P22706 Spindle Motor  
 P22002 Main C.B.A.

3. Remove 3 screws (Q) and then carefully take out the Traverse Unit.

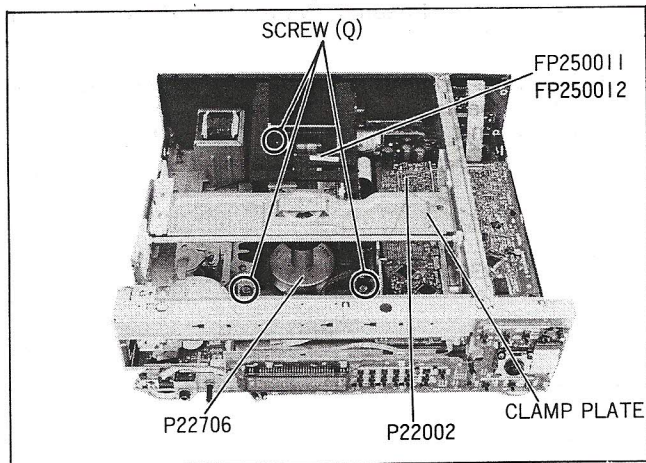

Fig. 7-1 Traverse Unit

## (2) Replacement of the Spindle Motor

1. Remove 3 screws (R) after removing Traverse Assembly from the unit. Remove the Spindle Motor by lifting it.

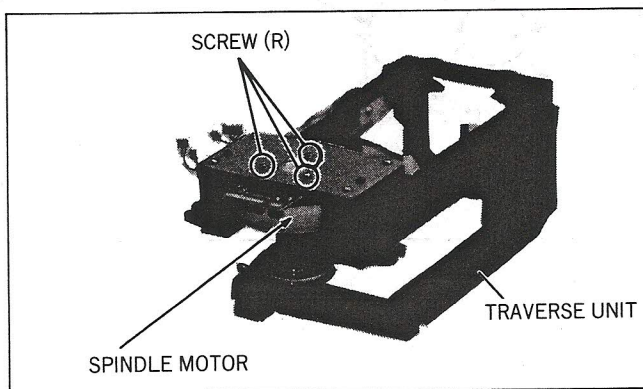

Fig. 7-2 Spindle Motor

## (3) Replacement of the Forward (Traverse) Motor

1. To replace the Forward Motor, perform item 1 to 3 of "Replacement of Pick-up Base" as shown in Fig. 8-1 and 2.

2. Remove 6 screws (S), (T) and (U) and C Ring for Flex. Cable Holder Spring then remove the Guide Base (L).

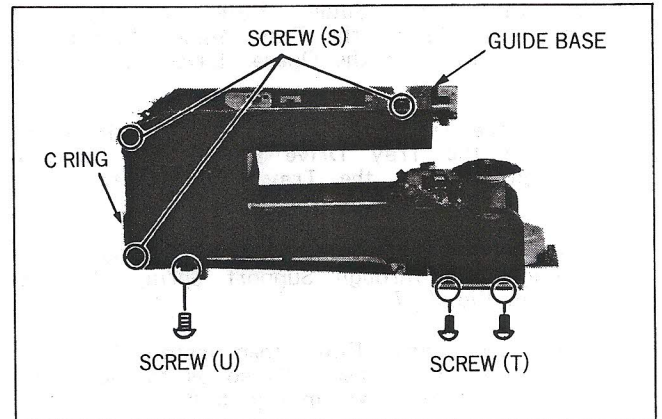

Fig. 7-3

3. Remove the Forward Belt Pulley and then remove 2 screws (V).

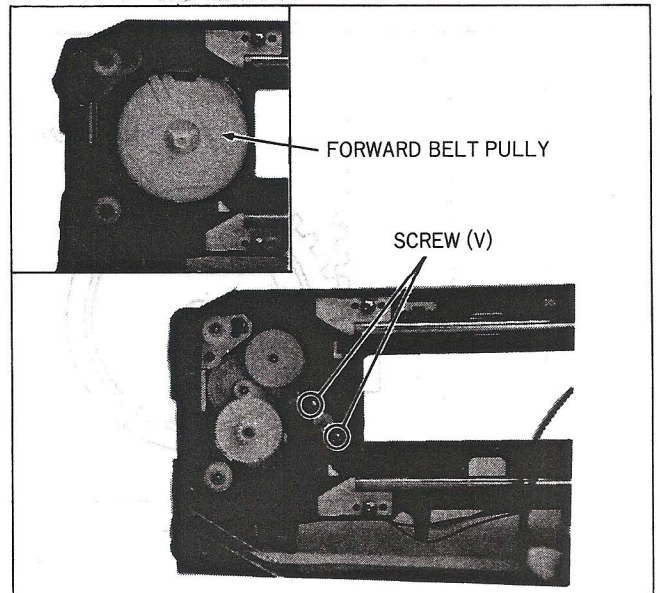

Fig. 7-4

# 8. REPLACEMENT OF PICK-UP

Use extreme care when replacing the Pick-up Base. Do not touch Focus Lens, Tilt Sensor and Photo Detector during servicing. After replacement of the Pick-up Base, readjust the Optical Pick-up and Servo Sections electrical adjustments.

Reassemble the Pick-up Base to Traverse Unit by following item 3 through 1 in reverse order.

## (1) Removal of the Pick-up Base

1. Disconnect the FP25011 of Interface C.B.A.
2. Move Pick-up Base assembly until the screw of the Belt Clamper can be seen through the frame and then remove the screw of the Belt Clamper.

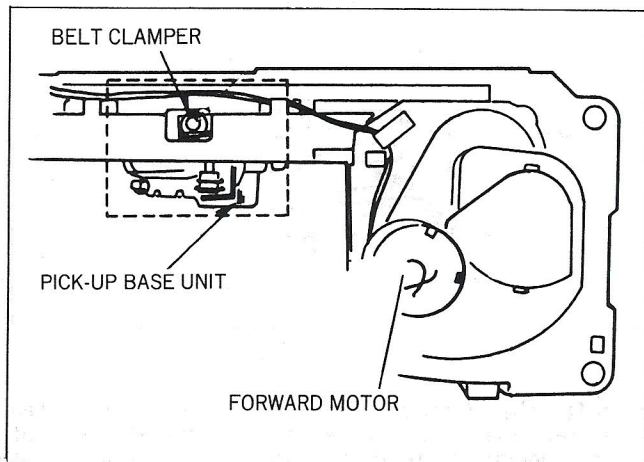

Fig. 8-1

3. Remove the Shaft Bearing screw. Carefully lift the Pick-up Base with the Guide Shaft (A) from the top side of the Traverse Unit.

<CAUTION>

It is not necessary to remove Switch Base (1) in order to remove Pick-up Base.

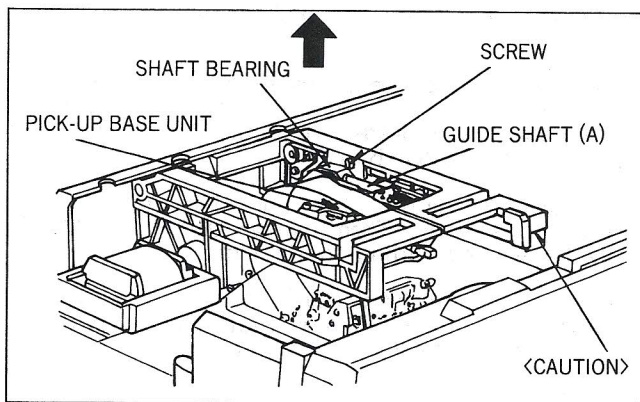

Fig. 8-2

<REASSEMBLY>

1. Move the Forward Belt Pulley as shown in Fig. 8-4. Reinstall the Belt Clamper.

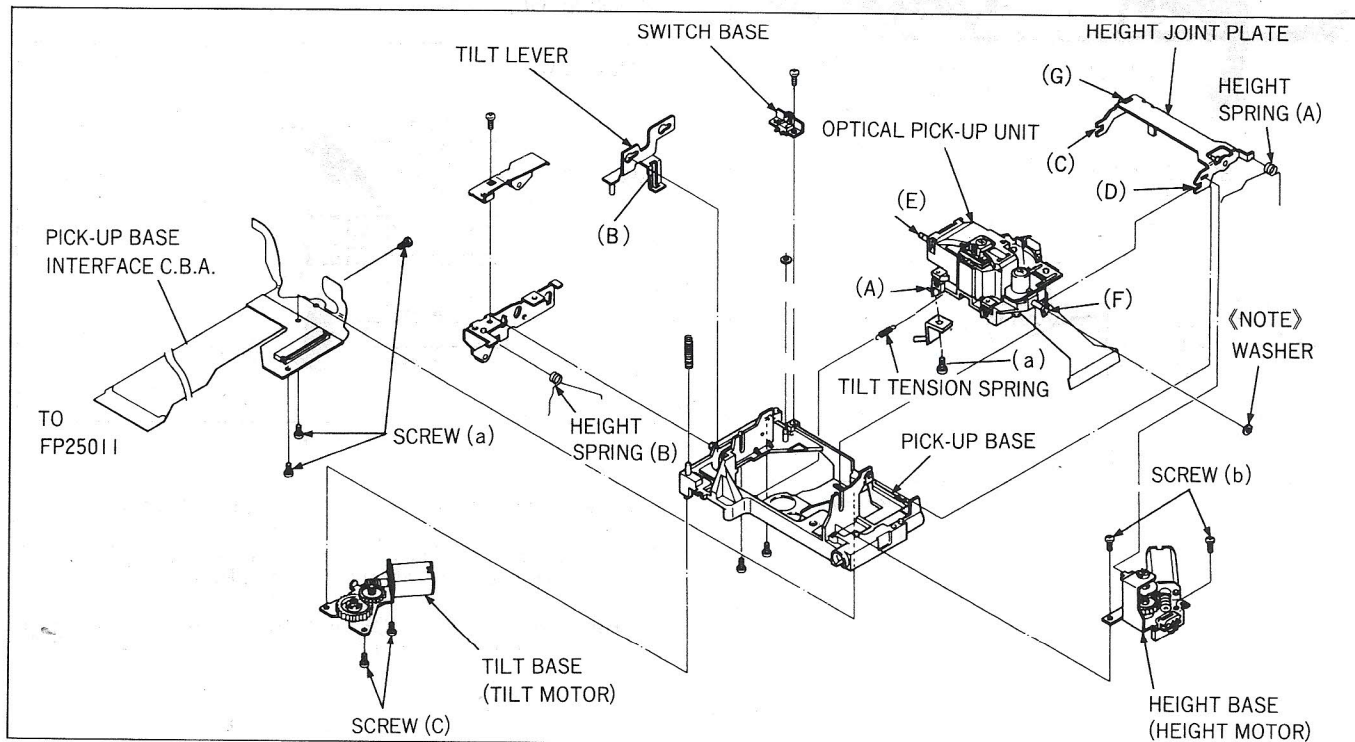

Fig. 8-3

2. Install the Pick-up Base on the Traverse Unit. Move the Pick-up Base and Belt Clamper by rotating the Belt Pulley so that the hole in the Pick-up Base aligns with hole in the Belt Clamper as shown in Fig. 8-1. Screw on the Pick-up Base.

(2) Replacement of the Optical Pick-up.

Reassemble the Optical Pick-up by following item 4 through 1 in reverse order.

1. Remove 4 screws (a) and disconnect connector P25001.
2. Unsolder the 2 leads from the Height Motor. If replacing the Pick-up Interface C.B.A., unsolder the 2 leads from the Tilt Motor and remove the Switch Base.
3. Remove 2 screws (b) and lift the Optical Pick-up a little. Then remove the Height Motor by lifting and pulling to the right.
4. Remove the Height Spring (A), (B), Tilt Tension Spring and Height Joint Plate. Then carefully remove the Optical Pick-up.

<NOTE>

Install the Washer on Shaft (F) on the new Optical Pick-up.

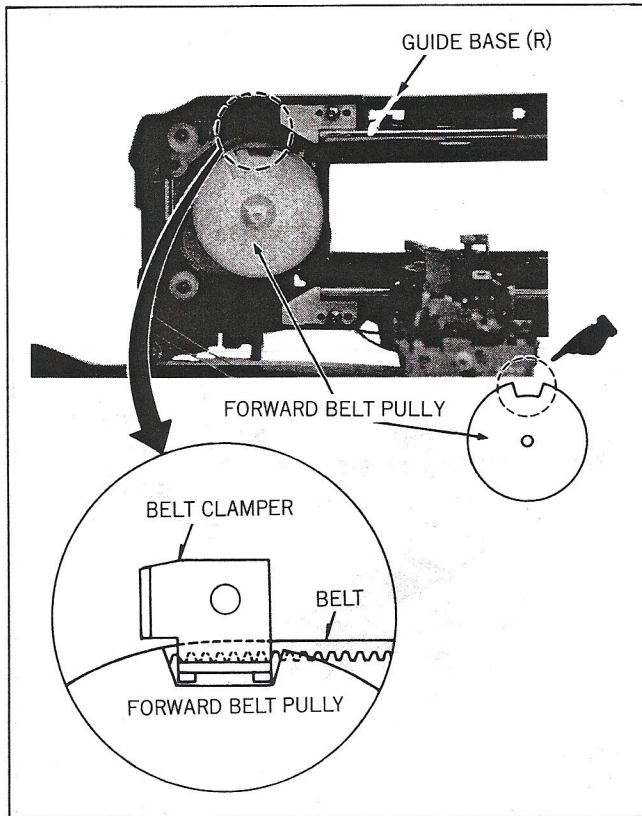

Fig. 8-4 Optical Pick-up

<REASSEMBLY>

1. Install the Optical Pick-up to Pick-up Base so that the Pin (A) of the Optical Pick-up meets the Hole (B) of the Tilt Lever. Then install the Tilt Tension Spring.
2. Lift the Optical Pick-up a little. Install the Height Joint Plate so that the Shaft (E) and (F) fit around (C) and (D).

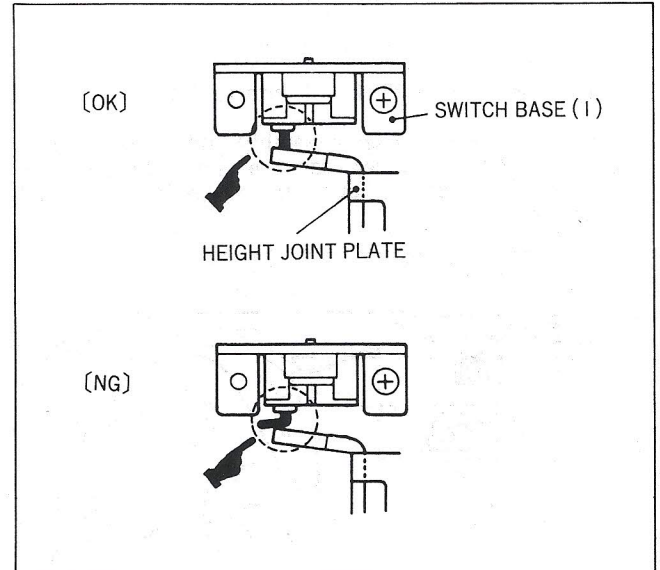

Fig. 8-5

3. Lift the Optical Pick-up a little and then install the Height Base so that the Pin (A) of the Height Joint Plate fits the (H) position of Height Base as shown in Fig. 8-6. Then install the Height Spring (A) and (B).

After replacement of the Optical Pick-up, readjust the Electrical Adjustment steps 2-1 "Tilt Balance A side Adj." to 2-4 "CD Focus & Tracking Gain Adj."

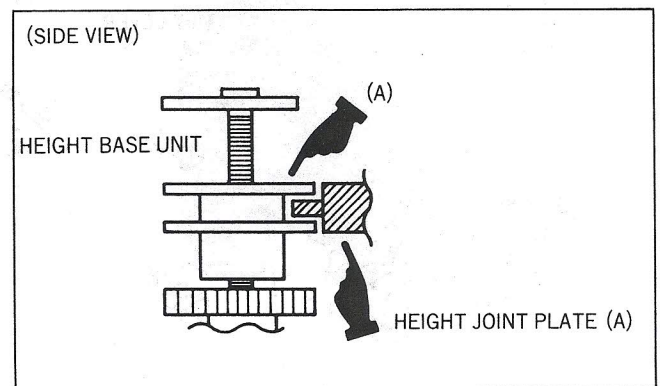

Fig. 8-6

(3) Replacement of the Tilt Base (Tilt Motor)

1. To replace the Tilt Motor, perform item 1 and 2 of "Replacement of the Optical Pick-up."
2. Remove 2 screws (C) and then take out the Tilt Motor as shown in Fig. 8-3.

<Alignment Procedures of Tilt Cam Gear>

Install the Tilt Cam Gear so that the Hole (A) on the Tilt Cam Gear aligns with Hole (B) on the Tilt Base. To facilitate aligning the hole use a small Hex. wrench or a metal pin. Install the Tilt Gear and then install the cut washer to mount Tilt Cam Gear and Tilt Gear. Install the Tilt Base so that the Pin (J) on the Tilt Lever aligns with the inner slot of Tilt Cam Gear.

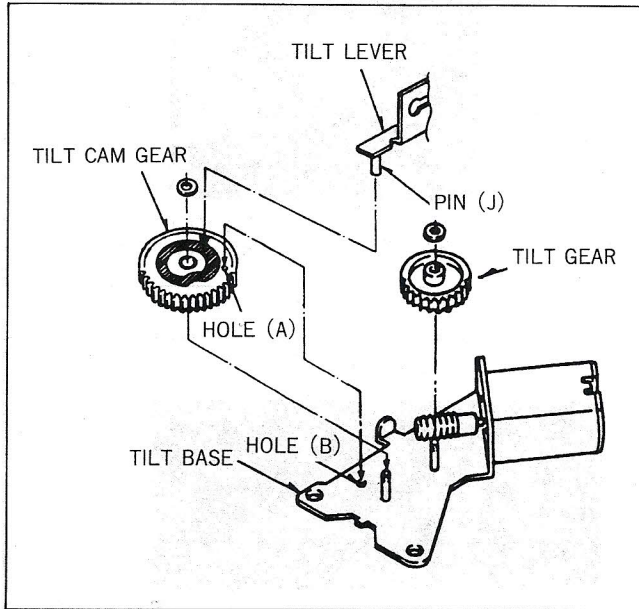

Fig. 8-7 Tilt Motor

(4) Replacement of the Tilt Sensor

1. Unsolder 4 leads from Sensor Base then remove the Tilt Sensor.
2. Place the new Tilt Sensor on the Sensor Base so that the position (A) of Tilt Sensor matches the upper right corner of Sensor Base as shown in Fig. 8-8. After replacement of the Tilt Sensor, readjust the Electrical Adjustment from step 1-1 "Tilt Sensor Adj." to item 2-4 "CD Focus & Tracking Gain Adj."

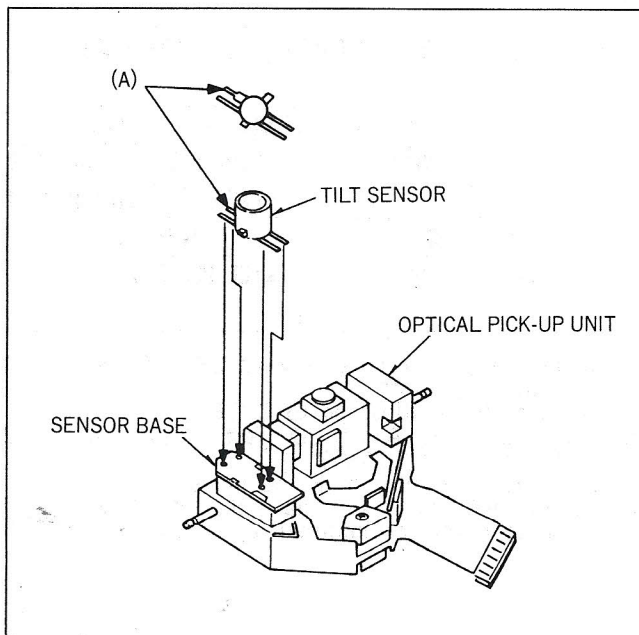

Fig. 8-8 Tilt Sensor

## 9. ELECTRICAL ADJUSTMENT

### 1. TEST & SERVICE EQUIPMENT

To perform the electrical adjustment completely, following equipment is required.

1. VTVM(Vacuum Tube Volt Meter) or DVM(Digital Volt Meter)  
Voltage Range : 0.001-50V
2. Dual-Trace Oscilloscope  
Voltage Range : 0.005-50V/div  
Frequency Range : DC-20MHz  
Probes : 10:1 or 1:1
3. Frequency Counter  
Frequency Range : 0-10MHz
4. Color Monitor TV
5. Plastic Tip Driver
6. LD Test Disc (VFK0652)
7. CD Test Disc (SZZP1054C)
8. Adjustment Table (VFK0539)
9. Extension Cable

VFK0706	12 PIN FLAT CABLE	FP22003 (MAIN) FP26203 (LOADING SW)
VFK0848	27 PIN FLAT CABLE	FP22001 (MAIN) FP25012 (INTERFACE)
VFK0850	8 PIN EXTENSION CABLE	P22002 (MAIN) LOADING/TRAVERS SW

Location of the Test Points and Controls for Servo Section.

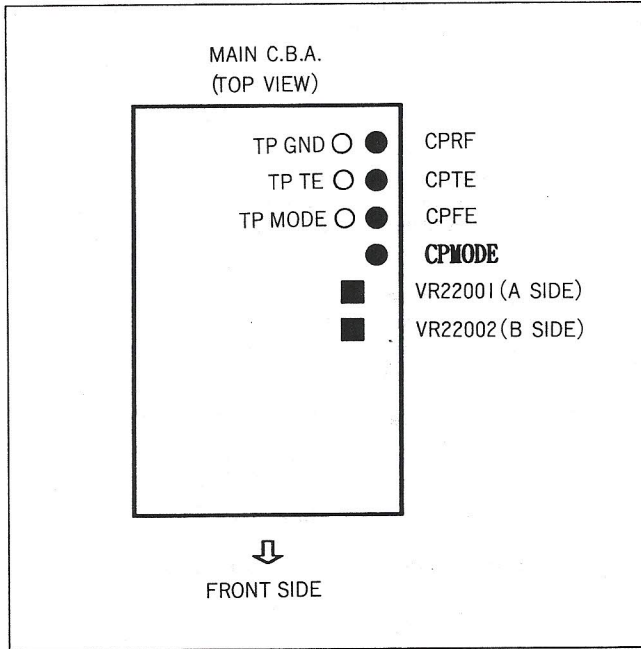

Fig. 9-1

These adjustment procedures consist of the following sections:

1. Optical Pick-up Section
2. Servo Section
3. Video Section
4. Audio Section

## 1. OPTICAL PICK-UP SECTION

### 1-1. TILT SENSOR ADJ

<NOTE>

If the spare parts for the Optical Pick-up have been adjusted, it is not necessary to readjust.

T P	ADJ.	MODE	DISC
CPTe	TILT SENSOR ADJ. SCREW	B SIDE P. B PAUSE	LD SIDE1 CAV CHAPTER19~21
M. EQ		SPEC.	
OSCILLOSCOPE		KICK PULSE IS MAXIMUM	

1. Connect the oscilloscope to CPTe.
2. Play back side B of LD Test Disc (Chapter 19 to 21 of Side 1(CAV)). Then place the unit in Pause Mode.
3. Adjust Tilt Sensor Adj. Screw so that Kick Pulse of Tracking Error signal is maximum.

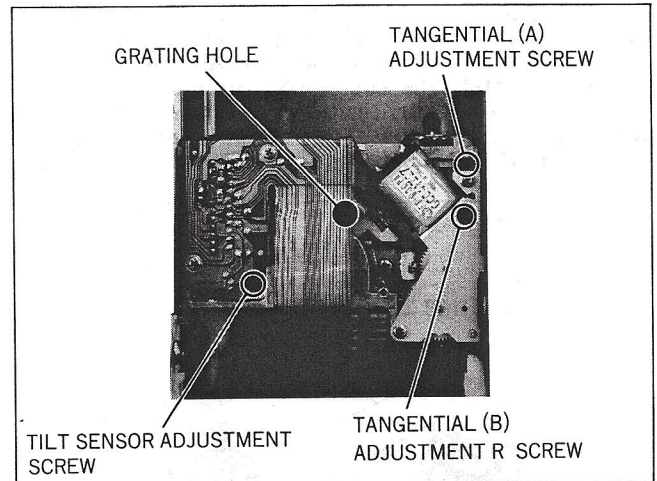

Fig. 9-2

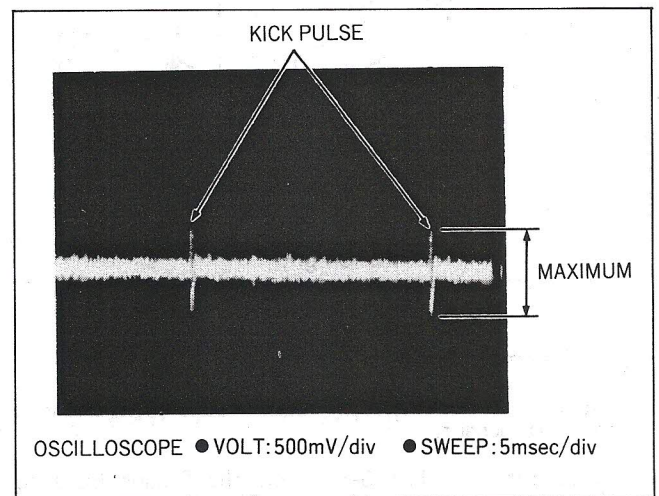

Fig. 9-3

## 2. SERVO SECTION

### 2-1. TILT BALANCE (A SIDE) ADJ.

T P	ADJ.	MODE	DISC
CPTe	VR22001	A SIDE P. B PAUSE	LD SIDE1 CAV CHAPTER12~14
M. EQ		SPEC.	
OSCILLOSCOPE		KICK PULSE IS MAXIMUM	

1. Connect a jumper wire between CPMODE and GND with the power off.
2. Connect the oscilloscope to CPTe.
3. Play back side A of LD Test Disc (Chapter 12 to 14 of side 1 (CAV)). Then place the unit in Pause mode.
4. Adjust VR22001 so that the Kick Pulse of Tracking Error is maximum as shown in Fig. 9-3.

## 2-2. TILT BALANCE (B SIDE) ADJ.

T P	ADJ.	MODE	DISC
CPT E	VR22002	B SIDE P.B PAUSE	LD SIDE1 CAV CHAPTER12-14
M. EQ		S P E C.	
OSCILLOSCOPE		KICK PULSE IS MAXIMUM	

1. Connect a jumper wire between CPMODE and GND with the power off.
2. Connect the oscilloscope to CPT E.
3. Play back side B of LD Test Disc (Chapter 12 to 14 of side 1 (CAV)). Then place the unit in Pause mode.
4. Adjust VR22002 so that the Kick Pulse of Tracking Error is maximum as shown in Fig. 9-3.

## 2-3. LD/CD FOCUS & TRACKING GAIN ADJ.

After completing the Tilt Balance A & B Side Adj, perform this adjustment.

T P	ADJ.	MODE	DISC
CPMODE	REMOTE CONTROLLER	A SIDE P.B P.B	LD SIDE1 CAV CHAPTER12-14 CD TRACK 1
M. EQ		S P E C.	
_____		_____	

1. Connect a jumper wire between CPMODE and GND with the power off.
2. Turn on the power and then play back side A of LD Test Disc (Chapter 12 to 14 of side 1 (CAV)).
3. Press the Audio Select Button on the Remote Controller to select L-CH (Adjust the Focus Gain automatically in the Servo IC). At this time, check that playback indication on the FIP by turning on and off.
4. After more than 5 second, change to R-CH (Adjust the Tracking Gain automatically in the Servo IC) by pressing the Audio Select Button on the Remote Controller. At this time, check the playback indication on the FIP by turning on and off.
5. After more than 5 second, change to Stereo by pressing the Audio Select Button.
6. Play back track 1 of CD Test Disc.
7. Press the Audio Select Button on the Remote Controller to select L-CH (Adjust the Focus Gain automatically in the Servo IC). At this time, check the playback indication on the FIP by turning on and off.
8. After more than 5 second, change to R-CH (Adjust the Tracking Gain automatically in the Servo IC) by pressing the Audio Select Button on the Remote Controller. At this time, check the playback indication on the FIP by turning on and off.
9. After more than 5 second, change to Stereo (Finish of adjustment) by pressing the Audio Select Button.
10. Remove jumper wire.

<NOTE>

To avoid mis-adjustment, use clean LD/CD Discs.

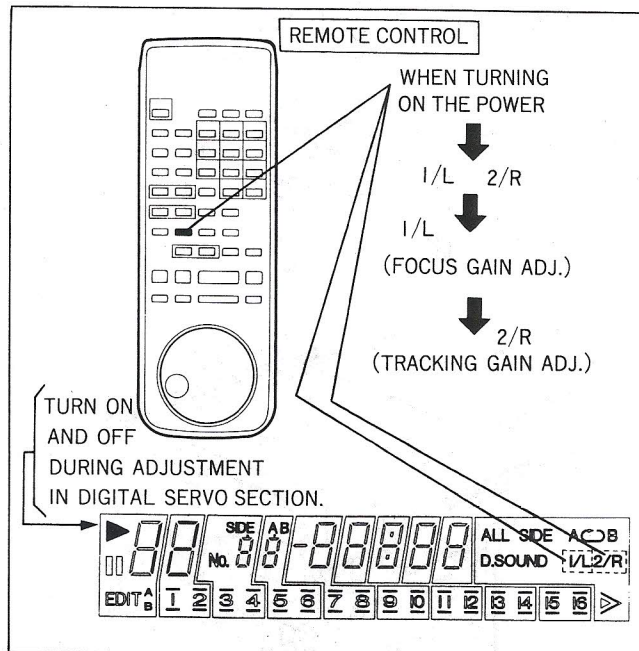

Fig. 9-4

## 2-4. CONFIRMATION

Play back tracks 7 and 13 of CD Test Disc. Then check that there is no skip. Play back the inner and outer side and place the unit in Chapter Search mode. Check the operation. If operation is not correct adjust the following items.

1. TANGENTIAL (A SIDE) ADJ.
2. GRATING ADJ.
3. TANGENTIAL (B SIDE) ADJ.

## 1. TANGENTIAL (A SIDE) ADJ.

T P	ADJ.	MODE	DISC
CPRF	TANGENTIAL (A) ADJ. SCREW	P. B	CD TRACK 11
M. EQ		S P E C.	
OSCILLOSCOPE		RF SIGNAL IS MAXIMUM	

1. Put the unit on the Adj. Table (VFK0539) to keep the unit horizontal while adjusting the bottom side. Connect the oscilloscope to CPRF. Do not place the unit on the left or right side as correct adjustment cannot be made. Though the Adjustment Table is supplied as fixture VFK0539, it can be fabricated locally using a metal frame.

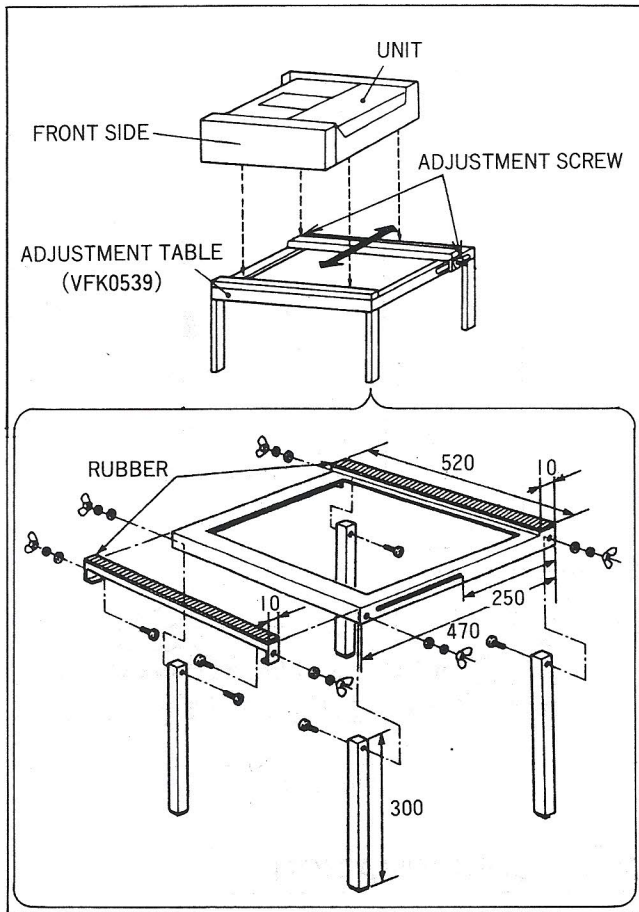

Fig. 9-5

2. Play back track 11 of CD Test Disc. Confirm that Tangential (A) Adjustment Screw (See Fig. 9-2) can be seen through adjustment hole on the Bottom Plate.

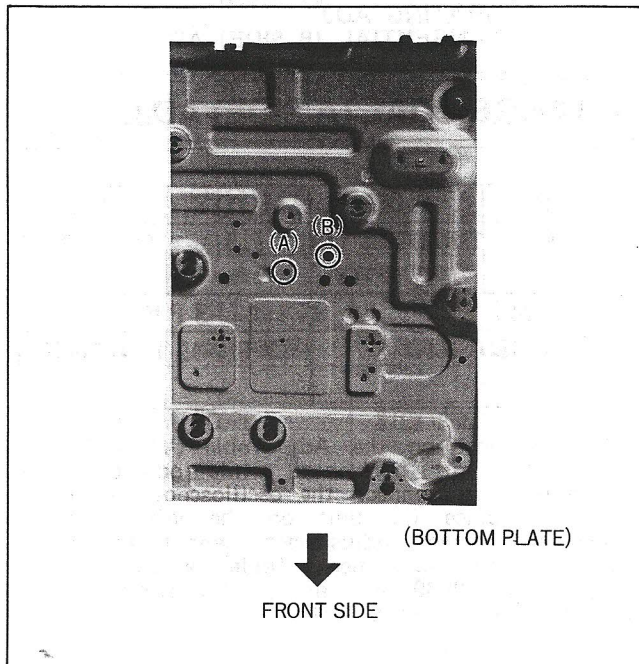

Fig. 9-6

3. Adjust Tangential (A) Adjustment Screw with a Hex Wrench (1.5mm) so that the width of the RF signal is maximum.

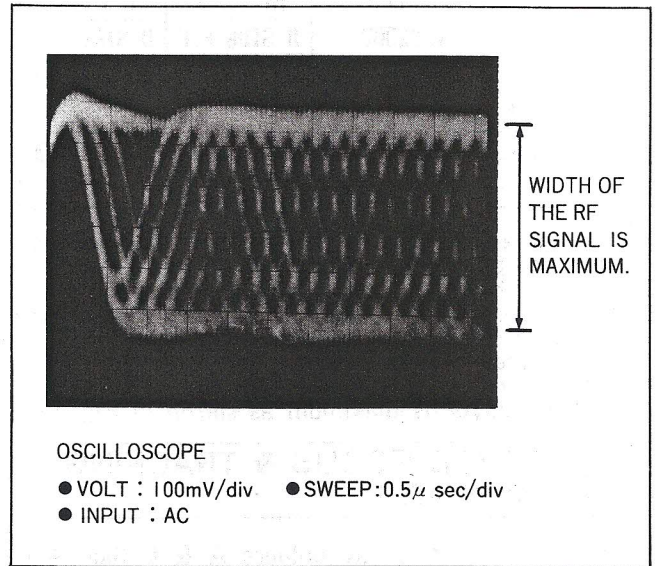

Fig. 9-7

## 2. GRATING

<CAUTION>

During adjustment, do not rotate Grating Adjust Pin too much (maximum  $\pm 2$  degree to 3 degree). If the Grating Adjust Pin is rotated too far the RF Signal can not be detected and further adjustment will not be possible.

T P	ADJ.	MODE	DISC
CPRF	GRATING HOLE	P. B	CD TRACK 11
CPTe		PAUSE	
M. EQ		SPEC.	
OSCILLOSCOPE		KICK PULSE IS MAXIMUM (REFER TO FIG. 9-3)	

1. Put on the unit on the Adjustment Table. Connect the oscilloscope to CPRF (CH1) and CPTe (CH2).
2. Play back track 11 of CD Test Disc. Then place the unit in Pause mode. Confirm that Grating Adjustment Screw (See Fig. 9-2) can be seen through the adjustment hole on the Bottom Plate.
3. Check that the Waveform (A) is as shown in Fig. 9-8.

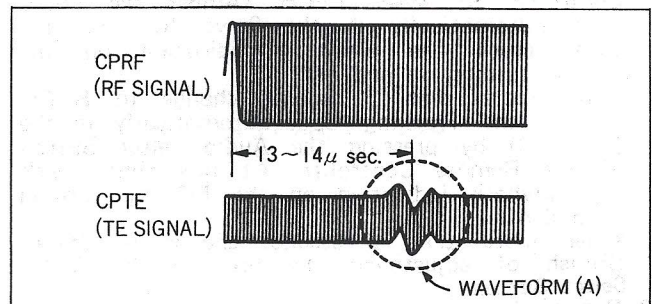

Fig. 9-8



- Place the unit in Pause mode. Confirm that Grating Adjustment Screw (See Fig. 9-2) can be seen through the adjustment hole on the Bottom Plate.
- Adjust the Grating Hole so that the Kick Pulse of Tracking Error is maximum as shown in Fig. 9-3.
- Place the unit in normal Play mode. Then confirm the Waveform (A) as shown in Fig. 9-8.

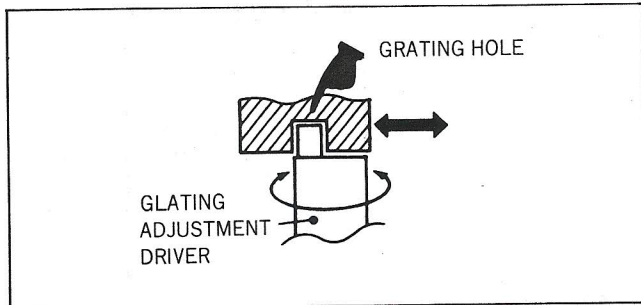

Fig. 9-9

### 3. TANGENTIAL (B SIDE) ADJ.

T P	ADJ.	MODE	DISC
CPRF	TANGENTIAL (B) ADJ. SCREW VR22002	B SIDE P. B	LD P. B
M. EQ		SPEC.	
OSCILLOSCOPE		RF SIGNAL IS MAXIMUM (REFER TO FIG. 9-7)	

- Connect the oscilloscope to CPRF.
- Play back side B of LD Test Disc. At this time, the Tangential (B) Adjustment Screw can be seen through the Traverse unit.

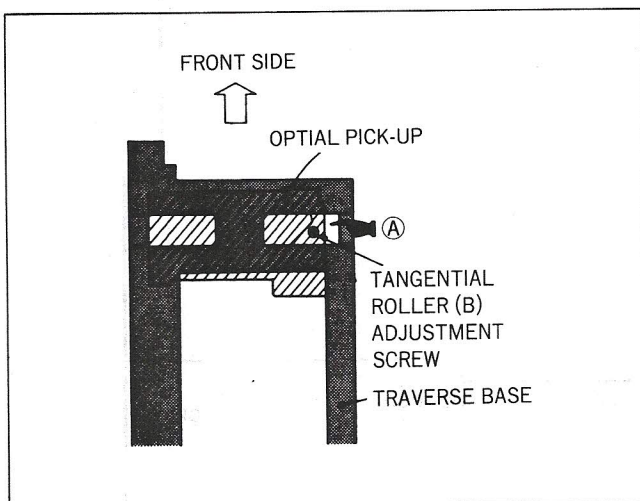

Fig. 9-10

- Adjust VR22002 and Tangential (B) Adjustment Screw alternately so that the width of the RF signal is maximum as shown in Fig. 9-7.

## 4. VIDEO RECTION SECTION

### 4-1. VIDEO PLAYBACK LEVEL ADJ.

T P	ADJ.	MODE	DISC
V. OUT 1 (JACK C. B. A)	VR23209	P. B	LD SIDE1 CAV CHAPTER 19
M. EQ		SPEC.	
OSCILLOSCOPE		1.00 ± 0.05 Vp-p	

- Connect the Video output terminal 1 with 75 ohm termination. Connect the oscilloscope to V. OUT 1 on the jack unit.
- Adjust VR23209 until the level of the Luminance signal is 1.00 ± 0.05 Vp-p.

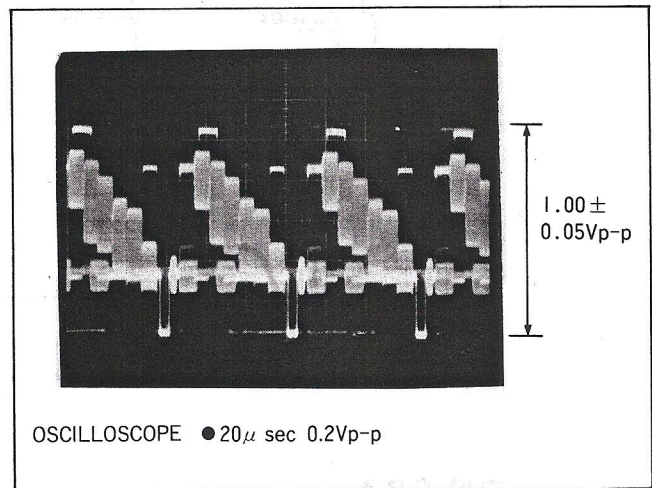

Fig. 9-11

## 5. AUDIO SECTION

### 5-1. VCXO ADJUSTMENT

T P	ADJ.	MODE	DISC
CP24007	VR24001	P. B	CD
M. EQ		SPEC.	
FREQUENCY COUNTER		16.9344MHz ± 300Hz	

# 5. LOCATION OF TEST POINTS & CONTROLS

